

3" Self-Priming Centrifugal Pumps

3" Self-Priming Pump



- **Cast Iron Construction with Stainless Steel Impeller**
- **Buna-N Mechanical Seal, Check Valve and O-Ring**
- **Optional Silicon Carbide Seal Available**
- **3" NPT Suction and Discharge Ports**
- **Maximum Solids Handling 3/8"**
- **Maximum Temperature 180° F**
- **Maximum Flow 375 GPM**
- **Maximum Head 110 Ft.**
- **Self-Priming to 20 Ft.**
- **Self-Cleaning, Semi-Open Impeller**
- **3 to 7-1/2 HP TEFC, Single and Three Phase Motors**
- **Optional Mounting Base Available**

AMT Self-Priming Cast Iron Centrifugal pumps are designed for a broad range of high capacity applications, including dewatering, liquid transfer, circulation, drainage and irrigation. Dual volute design reduces radial load on motor. The centerline discharge feature is specifically designed to prevent vapor binding and makes for convenient piping connections. All models are fitted with self-cleaning, semi-open stainless steel impeller, which can handle 3/8" diameter semi-solids. Built-in check valves for fast priming are standard on all units. Fill and drain plugs for easy installation and servicing.

Performance of Self-Priming Centrifugal Pumps

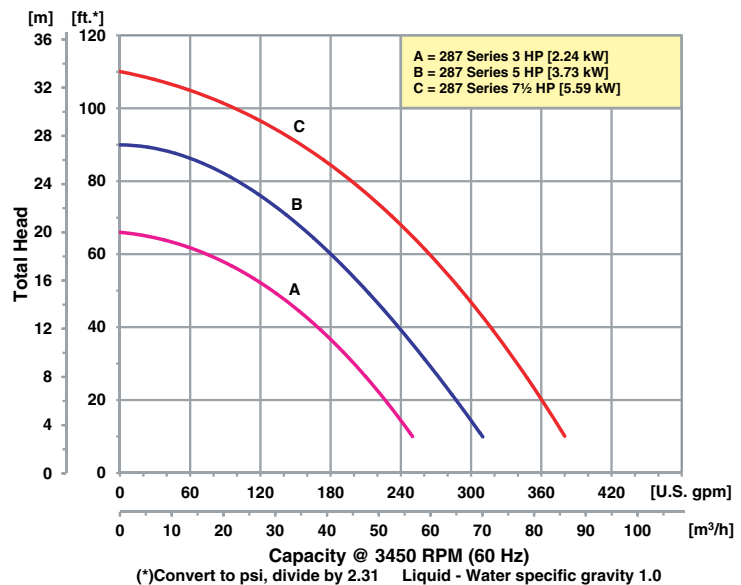

400 Spring Street • Royersford, PA 19468 USA

www.amtpump.com • 888-amt-pump (268-7867)

For use with nonflammable liquids compatible with pump component materials. Viton® and Teflon® are registered trademarks of E. I. DuPont.

Pump Dimensional & Specification Data

Model	Curve	HP	PH	Voltage @ 60 Hz +	Full Load Amps	Frame	SUC*	DIS*	A	B	C	L**	W**	H	Ship Wt. (Lbs.)
2877-95	A	3	1	230	16	184JM	3	3	3.7 [9.4]	17.1 [43.4]	5.5 [13.9]	29.1 [73.9]	13.7 [34.8]	11.8 [29.9]	133
2874-95		3	3	208-230/460	10/5	182JM	3	3	3.7 [9.4]	16.4 [41.6]	4.5 [11.4]	26.6 [67.6]	12.0 [30.5]	11.8 [29.9]	149
2878-95	B	5	1	230	21	184JM	3	3	3.7 [9.4]	17.1 [43.4]	5.5 [13.9]	29.1 [73.9]	13.1 [33.2]	11.8 [29.9]	205
2875-95		3	3	208-230/460	14/7	184JM	3	3	3.7 [9.4]	16.4 [41.6]	5.5 [13.9]	26.6 [67.6]	12.0 [30.5]	11.8 [29.9]	173
2879-95	C	7½	1	230	31	215JM	3	3	4.2 [10.6]	18.2 [46.2]	7.0 [17.8]	31.1 [79.0]	13.9 [35.3]	11.8 [29.9]	215
2876-95		3	3	208-230/460	20/10	184JM	3	3	3.7 [9.4]	16.4 [41.6]	5.5 [13.9]	26.6 [67.6]	12.0 [30.5]	11.8 [29.9]	176

(*) Standard NPT (Female) pipe thread.

(**) This dimension may vary due to motor manufacturer's specifications.

(+) 3-Phase models can also operate on 50 Hz (This will change full load amps and service factor, RPM and priming capabilities).

NOTE: Dimensions are in inches (centimeters) and have a tolerance of ± 1/4".

NOTE: Electric supply for ALL motors must be within ±10% of nameplate voltage rating (e.g. 230V ±10%= 207 to 253).

Optional Mounting Base Model A200-90

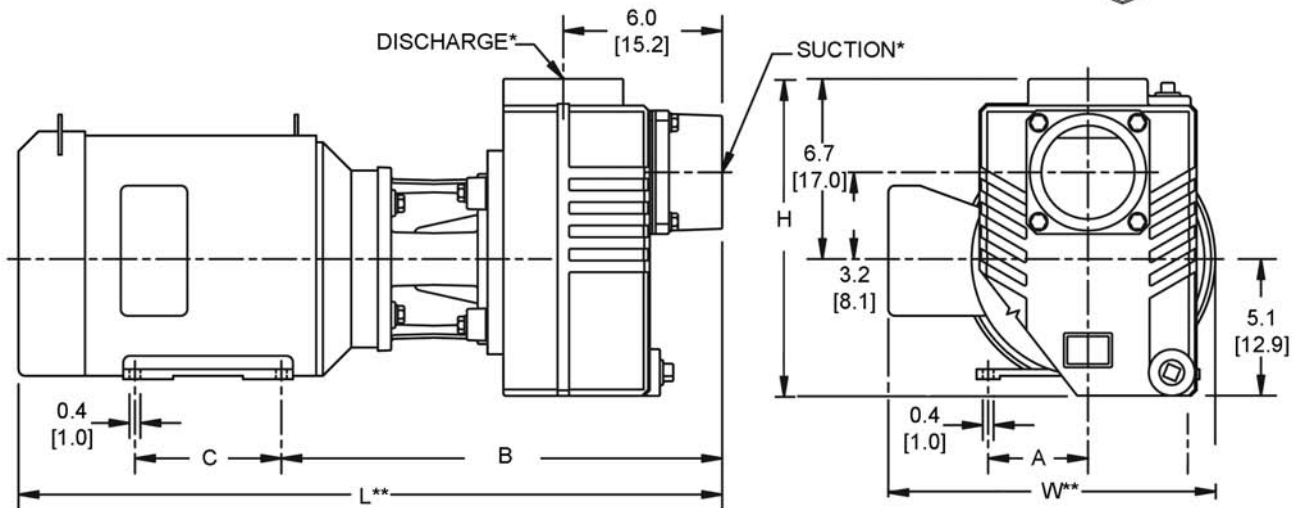

Standard Features

- Cast Iron Construction with Stainless Steel Impeller
- Buna-N Mechanical Seal and O-ring
- Optional Viton® Mechanical Seal and Flapper Valve Available
- Optional Silicon Carbide Seal Available
- 3" NPT Suction and Discharge Ports
- Stainless Steel Sleeve
- Dual Volute Design Reduces Radial Load on Motor
- Fill and Drain Plug for Easy Servicing
- Maximum Working Pressure 125 PSI
- Maximum Temperature 180° F
- Maximum Flow 375 GPM
- Maximum Head 110 Ft.
- Self-cleaning, Semi-open Impeller
- 3 to 7½ HP Totally Enclosed Fan Cooled (TEFC) Single or Three Phase Motors
- Optional Mounting Base Available on All Above Models
- QSP – Quick Ship Pump for Many Models

**Hazardous Duty/Xplosion Proof motors available from stock ranging from 1 to 10 HP;
CALL FOR QUOTATION & LEAD TIME!**